

NOTES:

- MATERIALS AND FINISHES
 BODY COMPONENTS - BRASS, NICKEL PLATED
 INNER BODY - BRASS, SILVER PLATED
 CONTACT - BRASS, SILVER PLATED
 INSULATOR - PTFE
- FOR ASSEMBLY PROCEDURE SEE AMPHENOL SPEC. 349-50244.
- CUSTOMER NOTE: WHEN CRIMPING CONTACT TO CABLE, AMPHENOL TOOL NO. 227-944 WITH DIE SET NO. 227-1221-13 CAVITY "B" IS RECOMMENDED.
- ASTERISK (*) INDICATES CABLE ENTRY DIMS.

31-4541		REVISIONS			
DRAWING NO.	REV	DESCRIPTION	DATE	ECO	APPR
THIRD ANGLE PROJ.	A	RELEASE TO MFG.	11/3/75	24033	SP
	R	NOTE #4 SPEC. 349-50551 SEC. 301 WAS NOTE #8 SPEC. 349-50551 SEC. 303	8/2/01	43633	MH
	T	DEL NOTE 3	6/27/05	45598	CPM

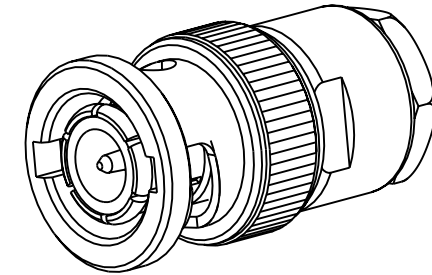

SCALE 2.000

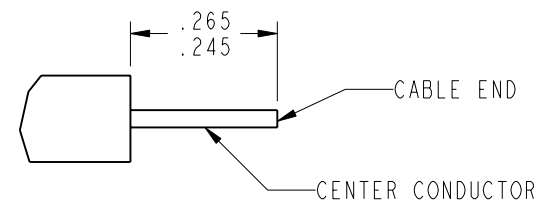
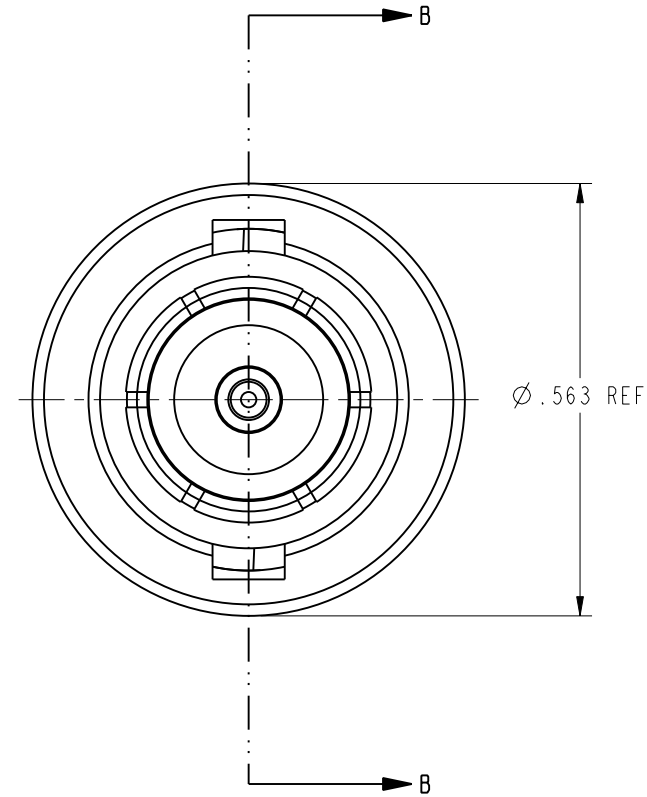
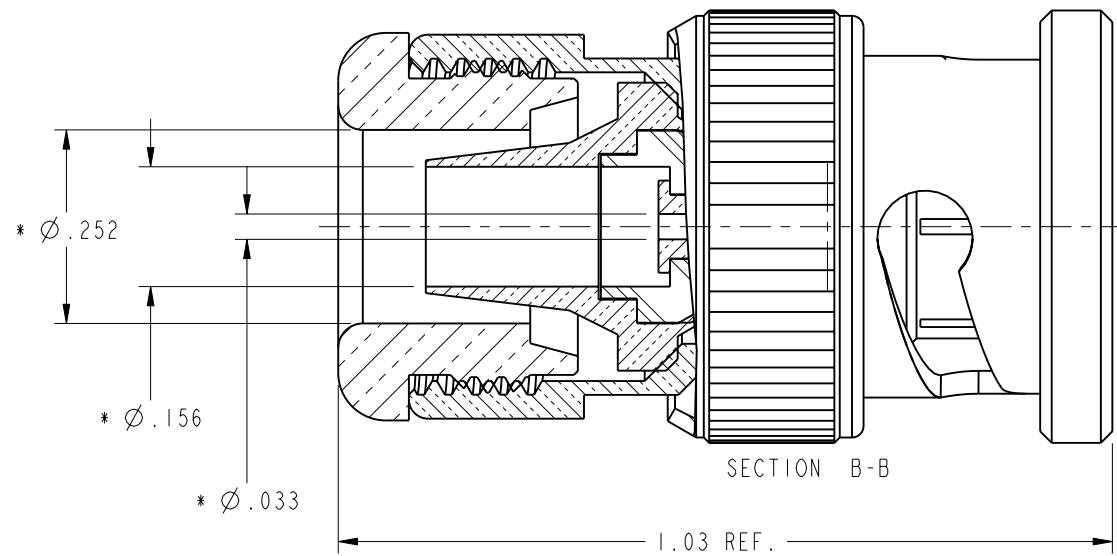

RECOMMENDED CABLE TRIM DIMENSIONS
SCALE 3.000

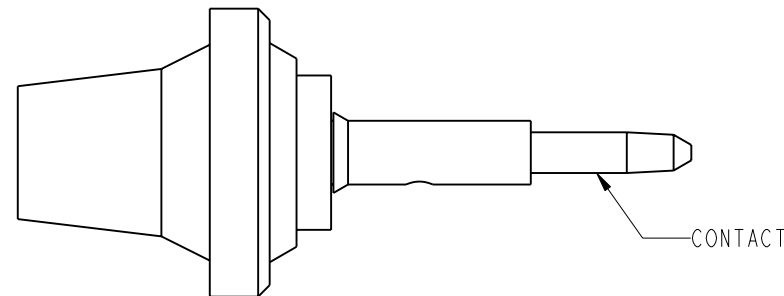

CUSTOMER OUTLINE DRAWING
ALL OTHER SHEETS ARE FOR INTERNAL USE ONLY

UNLESS OTHERWISE SPECIFIED, DIMENSIONS ARE IN INCHES AND TOLERANCES ARE: 2 PLACE DECIMAL $\pm .015$ (0,381 mm) 3 PLACE DECIMAL $\pm .005$ (0,127 mm) ANGLES $\pm 1^\circ$	MATERIAL	DRAWN MIKE HOYACK	DATE 30-Jul-01	TITLE BNC PLUG		Amphenol RF Danbury, CT, USA Tainan, Taiwan Shenzhen, China www.amphenolrf.com	
	REFERENCE	ENGINEER MIKE HOYACK	DATE 30-Jul-01				
NOTICE - These drawings, specifications, or other data (1) are, and remain the property of Amphenol Corp. (2) must be returned upon request; and (3) are confidential and not to be disclosed to any person other than those to whom they are given by Amphenol Corp. The furnishing of these drawings, specifications, or other data by Amphenol Corp., or to any other person to anyone for any purpose is not to be regarded by implication or otherwise in any manner licensing, granting rights or permitting such holder or any other person to manufacture, use or sell any product, process or design, patented or otherwise, that may in any way be related to or disclosed by said drawings, specifications, or other data.		APPROVED O. BARTHELMES	DATE 8/2/01	CODE ID 74868	DWG SIZE B	DRAWING NO. 31-4541	REV T
						SCALE: 4.0:1	SHEET 2 OF 2